

BOTONES DE PUERTA
COURTESY LIGHT SWITCHES

PULSADORES
PRESS BUTTONS

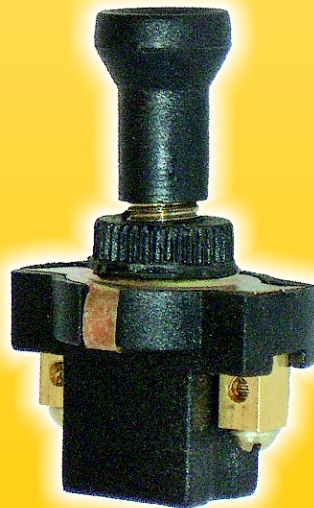

	11	1210
GENERAL MOTORS		
5/16"	TERMINAL CILINDRICO HEMBRA Ø 5	

		1211
GENERAL MOTORS		
	6,35	

	11	1212
GENERAL MOTORS		
M 10 x 1	TERMINAL CILINDRICO HEMBRA Ø 5	

	11	1215
DODGE		
M 10 x 1	TERMINAL CILINDRICO HEMBRA Ø 5	

	11	1216
DODGE		
M 10 x 1	TERMINAL CILINDRICO HEMBRA Ø 5	

AISLANTE NEGRO		1220
FIAT		
	6,35	

AISLANTE NEGRO		1221
FIAT		
	6,35	

		1222
FIAT		
	6,35	

		1223
FIAT		
	6,35	

AISLANTE NEGRO		1224
FIAT		
	6,35	

AISLANTE BLANCO		1230
FORD		

AISLANTE BLANCO		1231
FORD		

AISLANTE NEGRO		1232
FORD		

		1233
FORD		
	6,35	

AISLANTE NEGRO		1234
FORD		

		1235
PEUGEOT		

AISLANTE NEGRO		1240
PEUGEOT		
	5	

AISLANTE NEGRO		1247
PEUGEOT		
	5	

AISLANTE NEGRO		1250
RENAULT		

AISLANTE NEGRO		1251
RENAULT		
	5	



BOTONES DE PUERTA COURTESY LIGHT SWITCHES



AISLANTE NEGRO	1252
	
RENAULT	
	

AISLANTE NEGRO	1253
	
RENAULT	
	

AISLANTE NEGRO	1254
	
RENAULT - PEUGEOT - CITROEN	
	

	1260
	
VOLKSWAGEN	
	

AISLANTE NEGRO	1261
	
VOLKSWAGEN - SEAT	
	

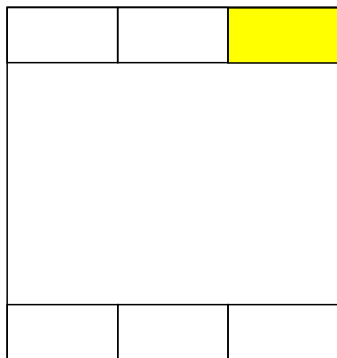
PULSADORES SWITCHES

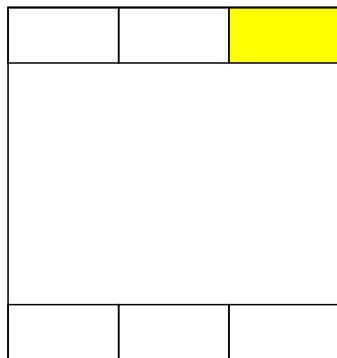

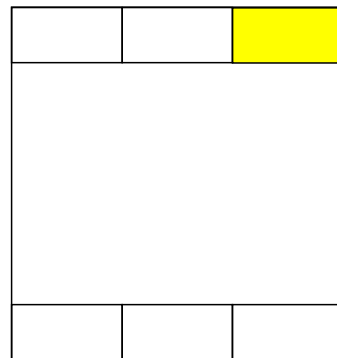
AISLANTE NEGRO	1540
	
MERCEDES BENZ TERMINAL TORNILLO	
	

AISLANTE NEGRO	1541
	
UNIVERSAL TERMINAL PALA	
	

